

Transformer Testing And Detection Of Fault

Prof. Priti S. Manware, Mohanish G. Lavhe, Shubham V. Gadpayle, Anjali J. Suryawanshi, Amit S. Taywade, Prekshana P. Patil

Assistant Prof.

Department of electrical Engineering, Priyadarshini Indira Gandhi College of Engineering
Nagpur, Maharashtra, India

rinky.manware@gmail.com mohnishlavhe30@gmail.com gadpayleshubham3@gmail.com
anjalisuryawanshi09@gmail.com amittaywade8956@gmail.com patil.prekshana.01@gmail.com

Abstract: The fault free operation of transformers is a very important factor for economic and safety considerations. This project emphasis on design of a prototype system capable of monitoring and reporting various parameters of transformer such as oil level, temperature, overloading, short circuit which may severely damage the transformer. Main controller of the system is ARDUINO UNO which controls all the sensors used. Temperature of winding is measured by LM35 temperature sensor and output is given to ARDUINO which is shown on the 16*2 LCD DISPLAY and if the temperature increases beyond preset limit then transformer is disconnected automatically using relays and an alert message will be sent through the GSM MODULE to the authority. Similarly current is measured by AC current sensor module and if its magnitude is found to be greater than normal operating current, then transformer will be shut down automatically with an alert message through SMS.

Hence, this project will limit the damage caused to transformer during abnormal condition and prevents the huge economic loss.

Index Terms : introduction, block diagram, methodology, advantages, application, future scope, result/conclusion, acknowledgement, reference.

I. Introduction

Transformer is the key equipment in power system, to ensure it is safe and stable operation is very important. Transformer either raise a voltage to decrease losses or decreases voltage to a safe level. Monitoring is here defined as on-line collection of data and includes sensor development and measurement techniques for on-line applications. It's very difficult and expensive to construct the communication wires to monitor and control each distribution transformer station. Here arduino is used as a communicating and monitoring of parameters.

The failures of transformers in service are Over Load, temperature rise, low oil level, Earth grounding, improper installation and maintenance. Out of these factors temperature rise, low oil levels and over load this parameter need continuous monitoring to save transformer life. A distribution transformer networks remote monitoring system increases the reliability of the system network by monitoring critical information for oil temperature, current and oil level of transformer. Data are collected continuously and also recorded. Monitoring the transformers for problems before they occur can prevent faults that are costly to fix and result in a loss of service life.

II. Block Diagram :

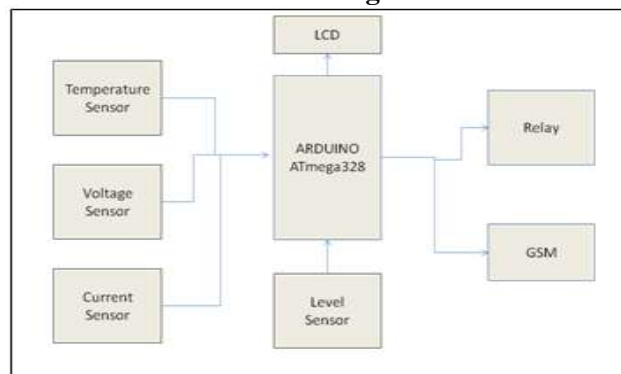

A. ARDUINO :

Arduino is an open- source hardware and software company, project and user community that designs and manufactures single-board microcontroller and microcontroller kits for building digital devices and interactive objects that can sense and control both physically and digitally. Its products are licensed under the GNU Lesser General Public License(LGPL) or the GNU General Public License, permitting the manufacture of arduino boards and software distribution by anyone. Arduino boards are available commercially in preassembled form or as do-it-yourself (DIY) kits. We use Microcontroller ATmega328P Operating Voltage: 5V Digital I/O Pins 14 (of which 6 provide PWM output) PWM Digital I/O Pins.6 Analog Input Pins .6 Flash Memory 32 KB (ATmega328P) 16 MHz frequency.

B. TRANSFORMER :

Electrical power transformer is a static device which transforms electrical energy from one circuit to another circuit without any direct electrical connection and with the help of mutual induction between two windings. It transforms power from one circuit to another without changing its frequency but may be in different level. Transformer are used for increasing or decreasing the altering voltage in electrical power application, and for coupling the stages of signal processing units. We use Single phase, 12 volt, 5amp transformer will be used. The transformer is based on the principle of mutual induction.

C. GSM (Global System for Mobile Communication)

A GSM modem is a device which can be either a mobile phone or a modem which can be used to make a computer or any other processor or microcontroller to communicate over a network. A GSM modem requires a SIM card to operate and operates over a network range subscribed by the network operator. It can be connected to a personal computer through serial, USB or Bluetooth connection.

D. 16*2 LCD DISPLAY

LCD (Liquid Crystal Display) is an electronic display module and has a wide range of applications. A 16x2 LCD display is basic module and is commonly used.. These modules are preferred over seven segments and other multi segment LED's. The reason is they are economical; easily programmable; have no limitation on displaying special characters ,animations and so on. A 16x2 LCD means it can display 16 characters per line and there are 2 such rows.

III. Methodology

The system is divided into two sections:

1. Transmitter
2. Receiver

Transmitter contain sensor which are used in project like oil level , temperature sensor i.e. LM35 and current sensor. and receiver contain Arduino contain microprocessor.

The end device contain different types of sensor. The sensors are used to sense the different parameters and send it to microcontroller. Microcontroller transmits through wireless transmitter.

The Receiver receives this data and displays it on the LED system and this whole process is real time monitoring parameters the transformer and also automation is automatically as well as manually are provided i.e. when the temperature is increases then automatically cooling system are ON and when the load is increases then automatically transformer is trip.

IV. Advantages

- Easy Operation.
- It has low maintenance cost and also reduce human efforts.
- No required of heavy machinery.
- Simple and reliable operation.

V. Application

- It has basic application i.e. for the purpose of protection of faults which is occur in transformer.
- The system can be implemented in industries

VI. Future Scope

We know that government distribution transformer which are place in society area , if the fault is occurred in the transformer due to overloading ,improper maintenance as well as earthing, increasing temperature and oil level due to this transformer is failure that time government are not interested to repair this

transformer . they directly replace new transformer because price of new transformer and repairing cost are near about same that why they direct place new transformer . so we design the system that we take the automation and monitoring of transformer . the system work are as follows . first all real data parameter like current, oil level and temperature of distribution transformer are monitor then if the fault is occurred like increasing temperature , overloading or oil level that time automation is work like if the temperature is increases then automatically fan are start for cooling purpose , if load is increases then relay sense the over current then command to microprocessor and microprocessor are get command to circuit breaker to trip the transformer and we are using ultrasonic sensor for measuring the oil level and this are automatically as well as manually from the control room and also display on control room.

VII. Result

Due to increased load of power system it is necessary to maintain communication between transformer health and operator so that any kind of abnormality does not cause large harm to the system. All data transfer must be important to keep healthy and power system reliability too. Use of Automation system makes such things possible very easily. Also automation system has less manual operation more accurate with modern technology it is possible to monitor a large number of parameters of transforelatively high cost. The challenge is to balance the function of the monitoring system and its cost and reliability.

VIII. Acknowledgement

The success and final outcome of this project required a lot guidance and benefits from the government and society people and I am extremely privileged to have got this all along the completion of our project. All that have done is only due to such supervision and assistance and I thanks to them.

References

- [1]. Abdul-Rahman Al-Ali, et al., "GSM-Based Distribution Transformer Monitoring System" IEEE MELECON 2004, May 12-15, 2004, Dubrovnik, Croatia.
- [2]. C.E. Lin, M. Ling, and C.L. Huang (1993). "An expert system for transformer fault diagnosis using dissolved gas analysis". IEEE Transactions on Power Delivery Yo1 8, No 1 January 1993.
- [3]. C. Bengtsson, "Status and Trends in Transformer Monitoring" IEEE Transactions on Power Delivery, Vol. 11, No. 3, July 1996.
- [4]. IEEE PC57.143 TM/D20, "Draft Guide for Application of Monitoring Liquid Immersed Transformers and their Components", March 2008.
- [5]. Liebfried, T., "Online Monitors Keep Transformers in Service", IEEE Computer Applications in Power, July 1998. p.36-42.
- [6]. CIGRE WG A2-27 "Recommendations for condition monitoring and condition assessment for transformers", 2007.
- [7]. "Experiences learned from the on-line internal monitoring of the behavior of a transformer", pp. TC3/11.1-TC3/11.3, 1997.
- [8]. Constantin Daniel Oancea, "GSM Infrastructure used for Data Transmission", 7th International symposium on Advanced Topics in Electrical Engineering (ATEE), 2011 May 12-14, Page(s): 1-4.
- [9]. SINGH, Jashandeep, et al. Novel method for detection of transformer winding faults using Sweep Frequency Response Analysis. In Power Engineering Society General Meeting 2007, pp. 1 – 9, IEEE Power & Energy Society, June 2007
- [10]. H.Wang Modeling Transformers With Internal Incipient Faults, Student Member,IEEE, and Karen L.Butler, Senior Member , IEEE Transactions On Power Delivery, Vol.17,no.2, April 2002 ,PP [500-509].
- [11]. Arduino <https://www.theengineeringprojects.com/2017/08/introduction-to-atmega328.html>